

# TECHNICAL DATA

TANDEM ROLLERS

BW 90 SC-5, BW 100 SC-5

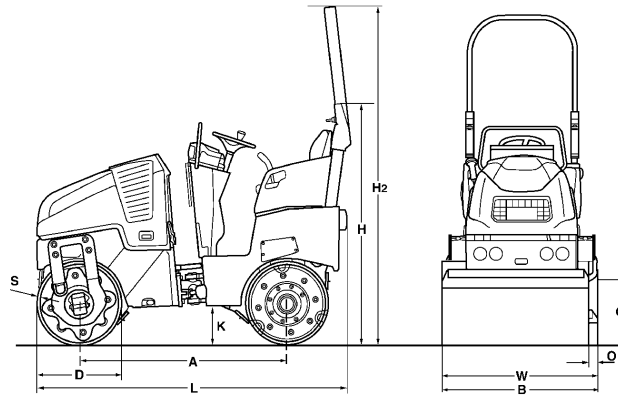



**Dimensions in mm**

	<b>A</b>	<b>B</b>	<b>C</b>	<b>D</b>	<b>H</b>	<b>H2</b>	<b>K</b>	<b>L</b>	<b>O</b>	<b>S</b>	<b>W</b>
<b>BW 90 SC-5</b>	1483	960	435	580	1627	2304	255	2194	52	12	960
<b>BW 100 SC-5</b>	1483	1060	435	580	1627	2304	255	2194	52	12	1060

**Shipping dimensions in m3**

**BW 90 SC-5**  
**BW 100 SC-5**

**without ROPS**

3,427  
3,784

**with ROPS**

4,853  
5,358

<b>Machine type</b>	<b>Compaction output (m3/h) at recommended soil layer thicknesses</b>		
	<b>Gravel, sand</b>	<b>Mixed soil</b>	<b>Silt, clay</b>
BW 90 SC-5	70-120	45-90	35-70
BW 100 SC-5	75-140	50-100	36-70

<b>Machine type</b>	<b>Compaction output (t/h) at different asphalt layer thicknesses</b>		
	<b>2-4 cm</b>	<b>6-8 cm</b>	<b>10-14 cm</b>
BW 90 SC-5	15-30	30-50	40-80
BW 100 SC-5	15-40	35-60	50-90

**Technical Data****BOMAG  
BW 90 SC-5****BOMAG  
BW 100 SC-5****Weights**

Operating weight CECE .....	kg	1.650	1.700
Average static linear load CECE .....	kg/cm	9,2	8,5
Grossweight .....	kg	1.900	1.900

**Dimensions**

Working width .....	mm	960	1.060
Track radius, inner .....	mm	2.000	1.950

**Driving Characteristics**

Speed .....	km/h	0- 10,0	0- 10,0
Working speed with vibration .....	km/h	0- 10,0	0- 10,0
Max. gradeability without/with vibr. ....	%	40/30	40/30

**Drive**

Engine manufacturer .....		Kubota	Kubota
Type .....		D 902	D 902
Emission stage .....		Stage V / TIER4f	Stage V / TIER4f
Cooling .....		water	water
Number of cylinders .....		3	3
Performance ISO 14396 .....	kW	15,1	15,1
Performance SAE J 1995 .....	hp	20,2	20,2
Speed .....	min-1	3.000	3.000
Speed adjustment 1 .....	min-1	2.100	2.100
Speed adjustment 2 .....	min-1	3.000	3.000
Electric equipment .....	V	12	12
Driven drum .....		front + rear	front + rear

**Brakes**

Service brake .....		hydrost.	hydrost.
Parking brake .....		hydromec.	hydromec.

**Steering**

Steering system .....		oscil.artic.	oscil.artic.
Steering method .....		hydrost.	hydrost.
Steering / oscillating angle +/- .....	grad	33/8	33/8
Crab walk .....	mm	0- 50	0- 50

**Exciter system**

Vibrating drum .....		front + rear	front + rear
Drive system .....		hydrost.	hydrost.
Frequency .....	Hz	42/63	42/63
Amplitude .....	mm	0,50	0,50
Centrifugal force .....	kN	8/19	8/19

**Sprinkler System**

Type of sprinkling .....		pressure	pressure
--------------------------	--	----------	----------

**Capacities**

Fuel .....	l	30,0	30,0
Water .....	l	100,0	100,0

Technical modifications reserved. Machines may be shown with options.

### Standard Equipment

- Side-clearance roller (drum offset 60-100 mm)
- Hydrostatic travel and vibration drive
- Travel drive in series
- 2 scrapers per drum, spring loaded and tiltable
- Pressure sprinkler system with interval switch
- Multi function travel lever
- Multi-function display incl. operating hour meter
- Water level
- Emergency STOP
- Individual control, vibration
- Intelligent Vibration Control (IVC)
- Integrated storage compartment
- Adjustable operator's seat
- Seat contact switch
- Vandalism protection
- 12V socket
- Working lights front and rear
- Back-up alarm
- Lockable engine hood made of composite material
- Lashing eyes, galvanized
- Single point lifting device

### Optional Equipment

- ROPS with safety belt
- \* Foldable ROPS incl. seat belt
- Sun roof, foldable with ROPS
- Double travel lever
- Seat heating
- BOMAG TELEMATIC
- Theft protection
- Indicator and hazard lights
- Rotary beacon
- Optional lighting on ROPS
- Battery disconnect switch
- Environmentally compliant hydraulic oil
- Special painting
- Edge cutter
- Port for hydraulik breaker
- Backup warning buzzer with broadband technology
- Temperature display
- ECOSTOP
- Outside mirrors
- Anti-frost intake
- Tablet holder set
- JOBLINK measuring technology interface
- JOBLINK Bluetooth adapter
- BOMAP GPS antenna holder

\* Standard delivery with CE conformity  
(valid within European Union)

