

TECHNICAL DATA

STABILIZERS/ RECYCLERS

RS 460, RS 500

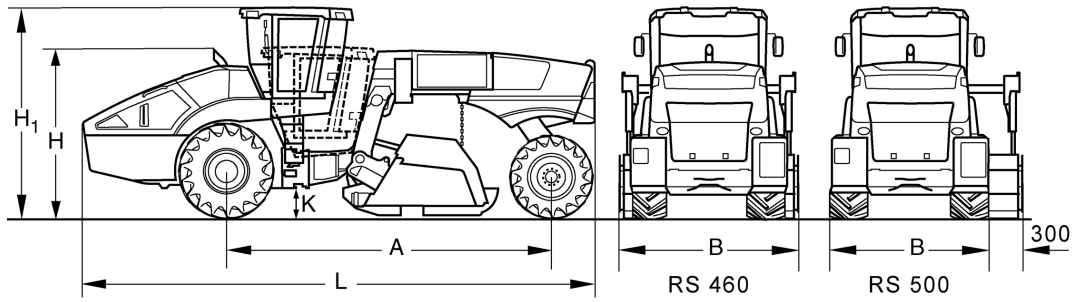



Dimensions in mm

	A	B	H	H1	K	L
RS 460	6073	2872	3100	3885	510	9579
RS 500	6073	2530	3100	3885	510	9579

Shipping dimensions in m3

RS 460	85,284
RS 500	75,128

Technical Data**BOMAG
RS 460****BOMAG
RS 500****Weights**

Operating weight CECE	kg	24.200	24.900
Axle load, front CECE	kg	16.050	16.030
Axle load, rear CECE	kg	8.150	8.870
Max. weight	kg	27.250	31.000

Driving Characteristics

Speed (1)	km/h	0- 3,0	0- 3,0
Speed (2)	km/h	0- 12,0	0- 12,0
Max. gradeability (dep. on soil con.)	%	40	40

Drive

Engine manufacturer		Merc.-Benz	Merc.-Benz
Type		OM 471 LA	OM 471 LA
Emission stage		Stage V / TIER4f	Stage V / TIER4f
Exhaust gas aftertreatment		DOC+DPF+SCR	DOC+DPF+SCR
Cooling		Liquid	Liquid
Number of cylinders		6	6
Performance ISO 9249	kW	340,0	390,0
Performance SAE J 1995	hp	456,0	523,0
Speed	min-1	1.600	1.600
Electric equipment	V	24	24
Drive system		hydrost.	hydrost.
Driven wheels		all wheel	AWD 4x4

Tyres

Tyre size, front		24.5-32 24PR	24.5-32 24PR
Tyre size, rear		23.1-26 20PR	23.1-26 20PR

Brakes

Service brake		hydrost.	hydrost.
Parking brake		multi disc	multi disc

Steering

Steering system		Art. + rear	Art. + rear
Steering method		hydraulic	hydraulic

Rotor

Rotor width	mm	2.440	2.250
Rotor diameter, outer	mm	1.224	1.224
Rotor speed	min-1	104- 179	100- 180
Rotor oscillation angle +/-	grad	8	8
Sense of rotation		up-cut	up-cut
Max. cutting depth	mm	500	500
Number of cutting teeth		160	160
Height of cutting teeth	mm	290	240

Capacities

Fuel	l	875,0	875,0
Water	l	850,0	850,0
AdBlue (DEF) ®	l	85,0	85,0

Technical modifications reserved. Machines may be shown with options.

Standard Equipment

- Hydrostatic drive / all wheel
- Anti Slip Control (ASC) (RS460)
- Hydr./ mech. rotor drive with autom. power control
- Rotor laterally slidable (RS500)
- Hydr. adjustable rotor inclination, automatic
- BOMAG FLEXMIX Technology (RS500)
- Universal rotor with exchange holder BMS15
- Hydr. tailgate with floating position+Load application function
- Hydrostatic articulated steering
- Hydrostatic rear axle steering
- 4 Steering modes
- Height adjustable ROPS cab
 - Transport/working position
 - slewable/slidable multi-function work place
 - heating
 - Air condition
 - Radio
- Working lights (LED)
- Rotary beacon
- Camera system Plus
- 4x Emergency STOP
- Air compressor + Connecting port for compressed air tools
- Lockable stowage compartments
- Central lubrication system (RS500)
- Rotary unit for rotor forward/reverse
- Pneumatic hammer for changing cutting tools
- compressed air system + Compressed air set

Optional Equipment

- Water metering system (900l + 1600l)
- Water prefilter
- Emulsion metering system 900l/min.
- Emulsion pre-filter for water system
- Dosing bar for cement suspension
- Printer for metering computer
- BOMAG SMART DOSING
- Rotor CMI-Layout 22mm
- Quick-change holder 20mm (BMS15)
- Rotor CMI-Layout 20mm
- Universal rotor BRS05 22mm
- Universal rotor BRS05 20mm
- High pressure cleaner
- Central lubrication system (RS460)
- Tool kit
- Quick refuelling system
- BOMAG TELEMATIC POWER
- Special painting
- Biodegradable hydraulic oil
- Widening of Track, front (RS500)
Overall width: 2.800mm
- Vibratory plate (RS460)

