

Technical sheet

MRT-X 2545 EASY 400

Rotating Telehandlers



Capacities		
Max. capacity	4500 kg	9920.80 lbs
Max. lift height	24.70 m	81 ft
Max. reach	19.40 m	63 ft 6 in
Dimensions		
l2 - Length to fork heel	7.06 m	23.16 ft
l1 - Overall length	8.26 m	27.10 ft
b1 - Overall machine width	2.50 m	8.20 ft
b8 - Overall width with stabilisers extended	4.98 m	16.30 ft
h17 - Overall height	3.02 m	9.91 ft
Wa3 - - Frame outer turning radius	5.52 m	18.10 ft
m4 - Machine ground clearance	0.32 m	1.05 ft
Standard tyres	Pneumatic	Pneumatic
Weight	15540 kg	34260 lbs
Stabilisers		
Type	Wing Type	Wing Type
Controls	Individual or Simultaneous	Individual or Simultaneous
Engine		
Brand	Perkins	Perkins
Environmental standards	1104D-44T	1104D-44T
Power	101 hp / 74.50 kW	- / 74.50 kW
Max. torque	392 Nm at -	289 ft.lbs at -
Number of cylinders - Capacity	4 - 4400 cm ³	4 - 268.50 in ³
Injection	Direct	Direct
Cooling	by Water	by Water
Transmission		
Type	Hydrostatic	Hydrostatic
Max. speed of travel (may vary according to the applicable regulation)	32 km/h	19.80 mph
Drawbar pull	7900 daN	17759.20 lbf
Parking brake	Automatic negative parking brake	Automatic negative parking brake
Service brake	Hydraulic	Hydraulic
Hydraulics		
Type of pump	Gear pump	Gear pump
Hydraulic flow rate	115 l/min	34.30 gpm
Pressure	270 bar	3916 psi
Tank capacities		
Hydraulic oil	150 l	39.60 US gal.
Fuel	130 l	34.34 US gal.
Noise & vibration		
Noise at driving position (LpA)	79.70 dB(A)	79.70 dB(A)
Noise to environment (LwA)	104 dB(A)	104 dB(A)
Vibration on hands/arms	<2.5 m/s ²	-

Dimensional drawing

Created on September 12, 2017 2:33 PM

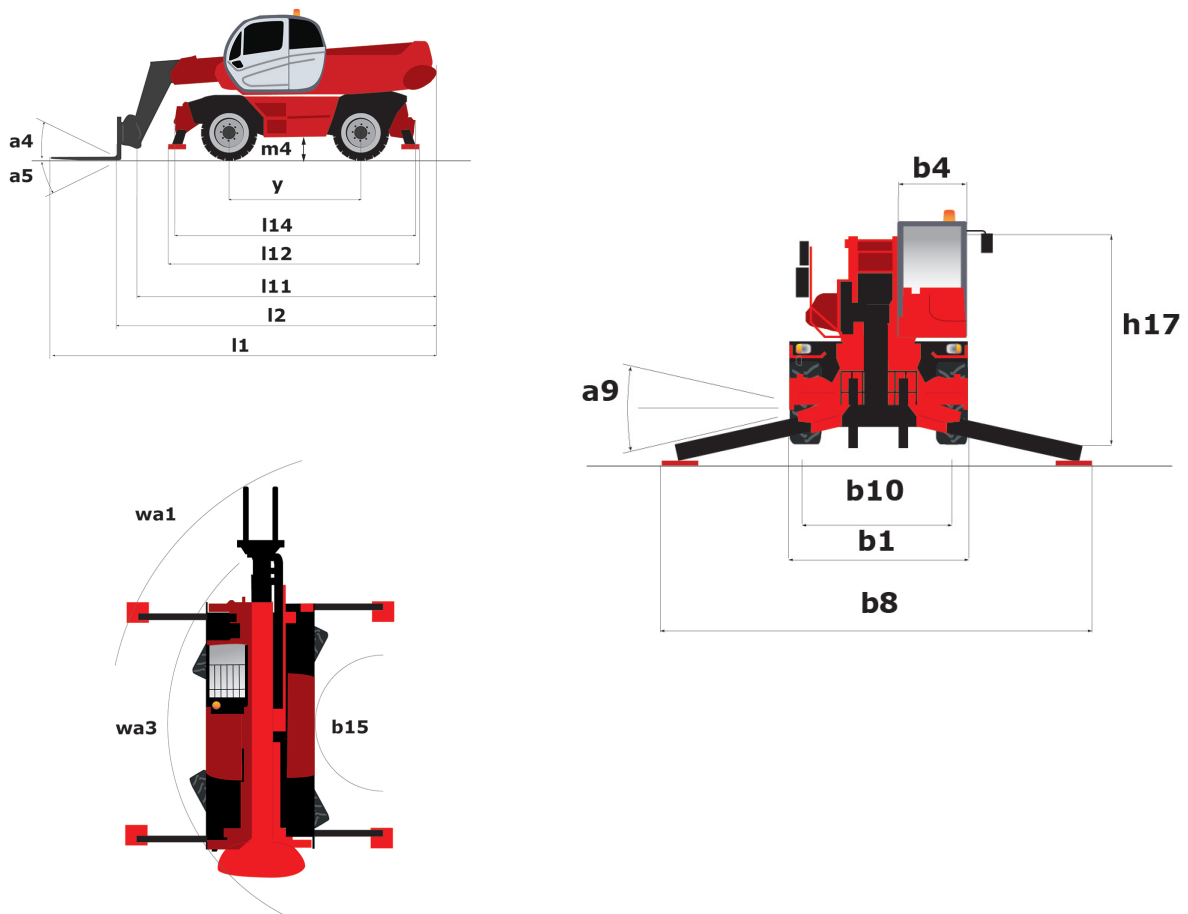

Other data	Metric
l11 - Overall length of fork carriage	7.06 m
l12 - Overall width at stabilisers	8.26 m
b8 - Overall width with stabilisers extended	4.98 m
y - Wheelbase	2.73 m
Wa1 - Outer turning radius (with forks)	5.52 m

Load chart

Created on September 12, 2017 2:33 PM

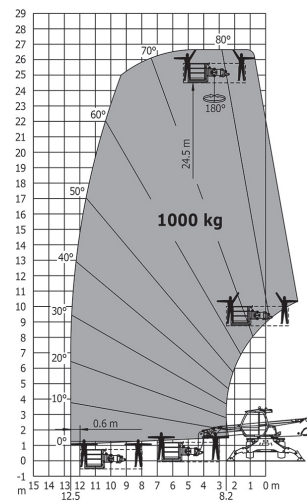
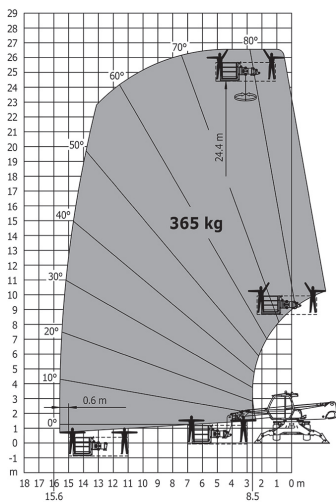
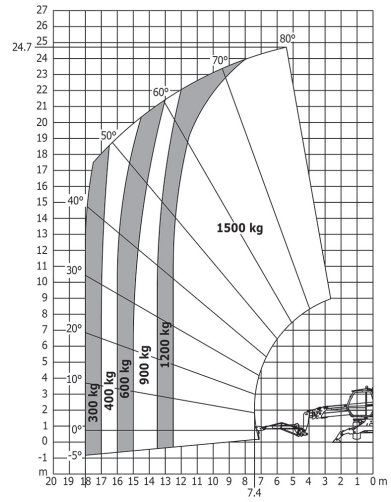
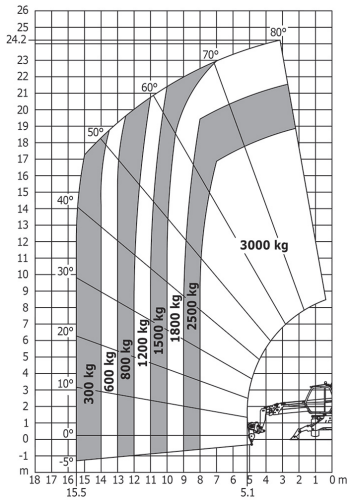
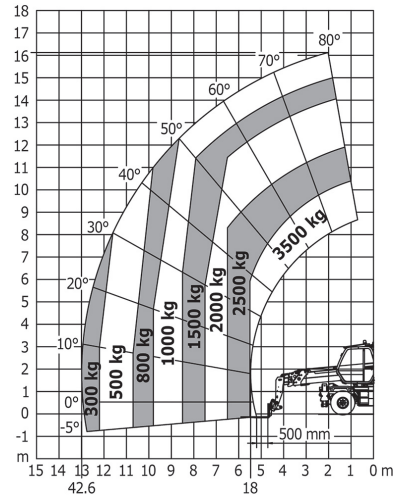
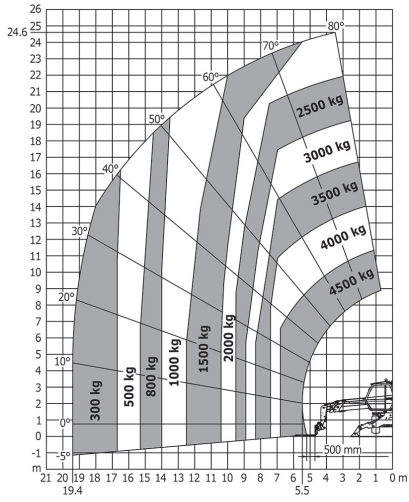



Siège Social
430 rue de l'Aubinière - 44150 Ancenis Cedex - France
Tel: +33(0)2 40 09 10 11 - Fax: +33 (0)2 40 09 10 97
www.manitou.com



This brochure describes versions and configuration options for Manitou products which may be fitted with different equipment. The equipment described in this brochure may be standard, optional or not available depending on version. Manitou reserves the right to change the specifications shown and described at any time and without prior warning. The manufacturer is not liable for the specifications given. For more information, contact your Manitou dealer. Non-contractual document. Product descriptions may differ from actual products. List of specifications is not comprehensive. The logos and visual identity of the company are the property of Manitou and may not be used without authorisation. All rights reserved. The photos and diagrams contained in this brochure are provided for information only.

MANITOU BF SA - Limited company with board of directors - Share capital: 39,547,824 euros - 857 802 508 RCS Nantes