

Technical sheet :

# **MSI 25 3B - FT4**

---



Technical characteristics			Metric
1.1	Manufacturer		Manitou
1.2	Model Name		MSI 25 3B / FT4
1.3	Power source		Diesel
1.4	Operator type		Seated
1.5	Max. capacity	Q	2500 kg
1.6	Load centre of gravity	c	500 mm
1.8	Load distance, centre of drive axle to fork	x	625 mm
1.9	Wheelbase	y	180 mm
Weight			
2.1	Service weight		4070 kg
2.2	Weight on front axle (laden) / rear axle (laden)		5695 kg / 875 kg
2.3	Weight on front axle (Unladen) / rear axle (Unladen)		1630 kg / 2440 kg
Wheels			
3.1	Tyres type		Pneumatic
3.2	Dimensions of front wheels		275/70 R22,5
3.3	Dimensions of rear wheels		7.00x12 14PR
3.5	Number of front wheels / rear wheels		2 / 2
3.5.2	Number of drive wheels		2
3.6	Front wheel gauge	b10	1040 mm
3.7	Rear wheel gauge	b11	1102 mm
Dimensions			
4.1	Tilt of Mast Forward (deg) / Backward (deg)	$\alpha / \beta$	10 / 12
4.12	Height of towing bar (coupling height)	h10	310 mm
4.19	Overall length	l1	4045 mm
4.20	Length to face of forks	l2	2945 mm
4.21	Overall width	b1	1323 mm
4.22	Forks section / width / length	s / e / l	40 mm x 100 mm / 1100 mm
4.23	Fork carriage ISO 2328 (class/form) A/B		2A
4.24	Fork carriage width	b3	1260 mm
4.31	Ground clearance below mast	m1	270 mm
4.32	Ground clearance at centre of wheelbase	m2	260 mm
4.33	Aisle Width for pallets 1000 x 1200 crossways	Ast	4525 mm
4.34	Aisle width for 800 x 1200 pallet lengthways	Ast	4625 mm
4.35	Turning radius	Wa	2545 mm
4.36	Internal turning radius (over tyres)	b13	150 mm
4.8	Seat height/stand height	h7	1025 mm
Performances			
5.1	Travel speed (laden / unladen)		20 km/h / 20 km/h
5.2	Lifting speed (laden / unladen)		0.40 m/s / 0.50 m/s
5.3	Lowering speed (laden / unladen)		0.50 m/s / 0.40 m/s
5.5	Drawbar pull (Laden / Unladen)		2280 daN / 1370 daN
5.7	Gradeability (laden / unladen)		31 % / 32 %
5.10	Service brake		Hydraulic
Engine			
6.1	Drive motor rating S2 60 min		48.60 kW
7.1	Engine brand / model		Kubota / V2403 CR TE4
7.2	Engine power according to ISO 1585		48.60 kW
7.3	Rated speed		2700 rpm
7.4	Number of cylinders / Capacity of cylinders		4 - 2434 cm <sup>3</sup>
Miscellaneous			
8.1	Type of drive control		Hydraulic
8.2	Working hydraulic pressure for attachments		170 Bar
8.3	Oil flow rate for attachments		45 l/min

## MSI 25 3B - FT4 - Dimensional drawing

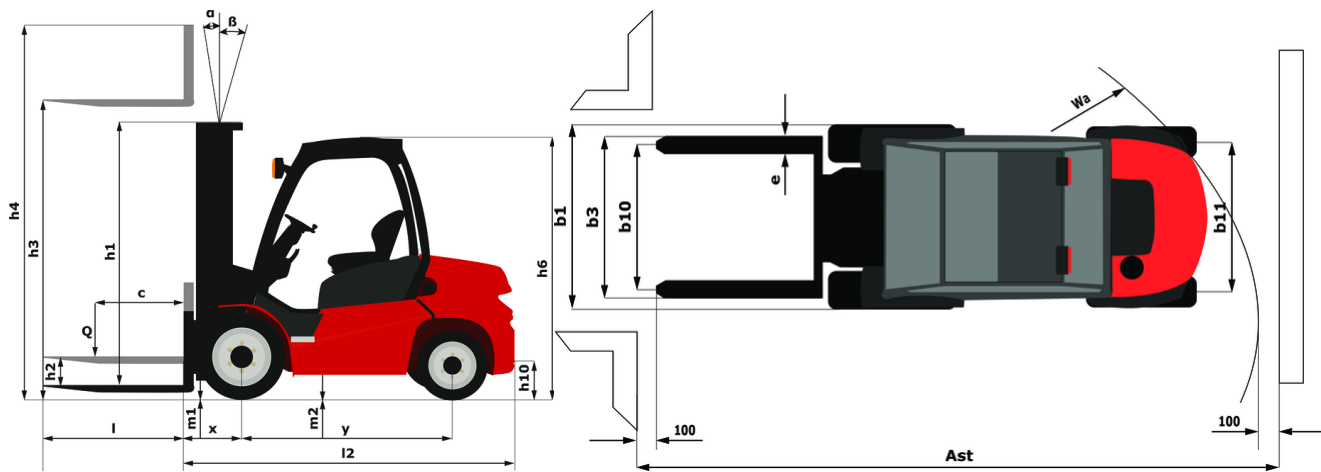

## Characteristics of masts and residual capacities

Full Visibility Duplex		FVD 27	FVD 30	FVD 33	FVD 35	FVD 37	FVD 40	FVD 45	FVD 50
h2 - Free lift	mm	130	130	130	130	130	130	130	130
h1 - Height mast lowered *	mm	2000	2150	2300	2400	2560	2750	3000	3250
h3 - Lifting Height	mm	2700	3000	3300	3500	3700	4000	4500	5000
h4 - Height mast extended *	mm	3531	3831	4131	4331	4531	4831	5331	5831
$\alpha / \beta$ - Mast inclination (front / rear)	°	10 / 12	10 / 12	10 / 12	10 / 12	10 / 12	10 / 12	10 / 12	10 / 12
Residual capacity at max height	kg	2500	2500	2500	2500	2500	2500	2200	1900
Height at max capacity with integrated sideshift	mm	0							

Free Lift Triplex		FLT 37	FLT 40	FLT 43	FLT 47	FLT 50	FLT 55	FLT 60	FLT 65	FLT 70
h2 - Free lift	mm	1221	1321	1421	1571	1671	1831	2021	2271	2521
h1 - Height mast lowered *	mm	1950	2050	2150	2300	2400	2560	2750	3000	3250
h3 - Lifting Height	mm	3700	4000	4300	4700	5000	5500	6000	6500	7000
h4 - Height mast extended *	mm	4469	4769	5069	5469	5769	6269	6769	7300	7770
$\alpha / \beta$ - Mast inclination (front / rear)	°	10 / 12	10 / 12	10 / 12	10 / 12	10 / 12	10 / 12	10 / 12	10 / 12	10 / 12
Residual capacity at max height	kg	2500	2500	2400	2100	1900	1500	1500		
Residual capacity without attachment (Industrial load chart)	kg	2500	2500	2400	2100	1900	1500	1500		

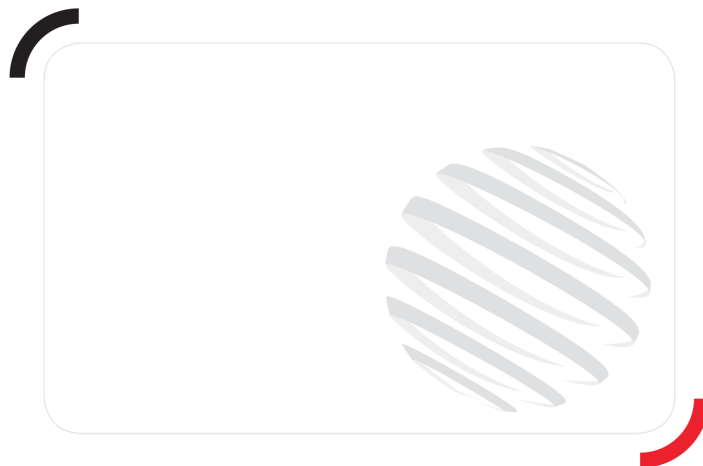

Siège Social

430 rue de l'Aubinière - 44150 Ancenis Cedex - France

Tel: +33(0)2 40 09 10 11 - Fax: +33 (0)2 40 09 10 97

[www.manitou.com](http://www.manitou.com)



This brochure describes versions and configuration options for Manitou products which may be fitted with different equipment. The equipment described in this brochure may be standard, optional or not available depending on version. Manitou reserves the right to change the specifications shown and described at any time and without prior warning. The manufacturer is not liable for the specifications given. For more information, contact your Manitou dealer. Non-contractual document. Product descriptions may differ from actual products. List of specifications is not comprehensive. The logos and visual identity of the company are the property of Manitou and may not be used without authorisation. All rights reserved. The photos and diagrams contained in this brochure are provided for information only.

MANITOU BF SA - Limited company with board of directors - Share capital: 39,668,399 euros - 857 802 508 RCS Nantes