

MRT & MRT-X 3255

PRIVILEGE +

TECHNICAL DATA SHEET



 **MANITOU**

www.manitou.com

MRT & MRT-X 3255

PRIVILEGE +

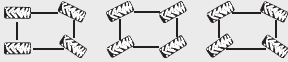
	MRT 3255 Privilege +	MRT-X 3255 Privilege +
Lifting		
Max. capacity with forks at 600 mm LC (on stabilizers)	5 500 kg	
Max. capacity with winch 7200 Kg (on stabilizers)	7 200 kg	
Max. lifting height	31.60 m	
Max. outreach	27.20 m	
Tyres	17.5/R25	
Suspension / Frame levelling		
	Electronically controlled hydropneumatic suspension	
Lateral frame levelling	+/- 8°	
Longitudinal frame levelling	+/- 3°	
	Oscillating rear axle with automatic hydraulic lock when rotated (> 15°)	
Stabilizers		
	4 Triplex telescopic Simultaneously or individually controlled	
Full, continuous rotation		
	Turret mounted on a double slewing with internal gearing / slewing system with negative brake	
Braking		
Service brake	Oil-bath multiple-disc brakes hydraulically assisted on both axles	
Parking brake	Automatic Negative Parking brake	
Engine		
	MERCEDES	
Type	OM 934 LA.E4-1 (Stage IV / Tier IV final)	OM 924 LA.E3A/1 (Stage IIIa / Tier III)
Displacement	4 cylinders 5.1 liters	4 cylinders 4.8 liters
Power	231 HP / 170 kW	197 HP / 145 kW
Max. torque	900 Nm / 1200-1600 rpm	705 Nm / 1200-1600 rpm
Batteries	24 V: 2 x 12 V - 120 Ah - 850 A	
Laden drawbar pull	10 500 daN	
Gradability	40%	
Transmission		
	Continuous Variable Transmission DANA 319 Permanent 4 wheel drive	
	4 wheel steer - 3 Steering Modes	
Steering mode		
Max. travel speed (may vary according to applicable regulations)	40 kph	
Controls		
	2 Joysticks multi - functions	
Hydraulics		
Load sensing Pump	210 l/min - 350 bar Axial piston variable pump	
Capacities		
Urea (AdBlue® type)	54 l	-
Hydraulic oil	297 l	
Fuel	361 l	
Unladen weight (with forks)		
	23 986 kg	
Dimensions		
Overall width	2.50 m	
Overall width (stabilizers extended)	7.10 m	
Overall height	3.20 m (+/- 0.078 m)	
Overall length to carriage	8.50 m	
Ground clearance	0.42 m (+/- 0.078 m)	
Turning radius (over tyres)	4.91 m	
Standard forks (length x width x thickness)	1200 x 150 x 60 mm	
Safety		
	Load monitoring system - (crane norms) Attachment recognition system (E-Reco)	
Noise and vibration		
Noise at driving position (LpA)	80 dB	
Environmental noise (LwA)	106 dB	
Vibration to whole hand/arm	<2.5 m/s ²	

MRT & MRT-X 3255

PRIVILEGE +

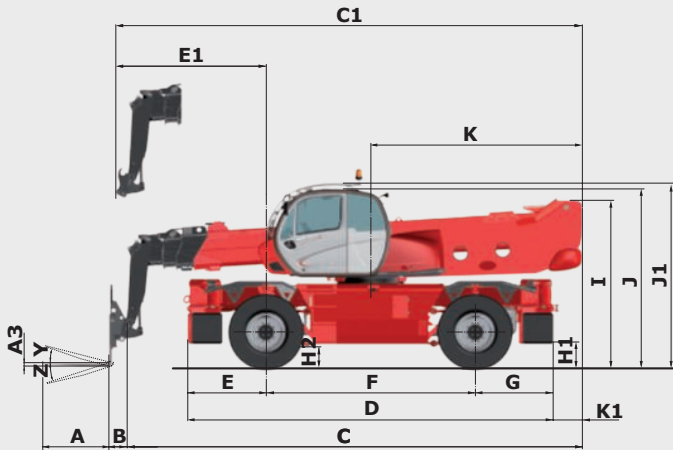
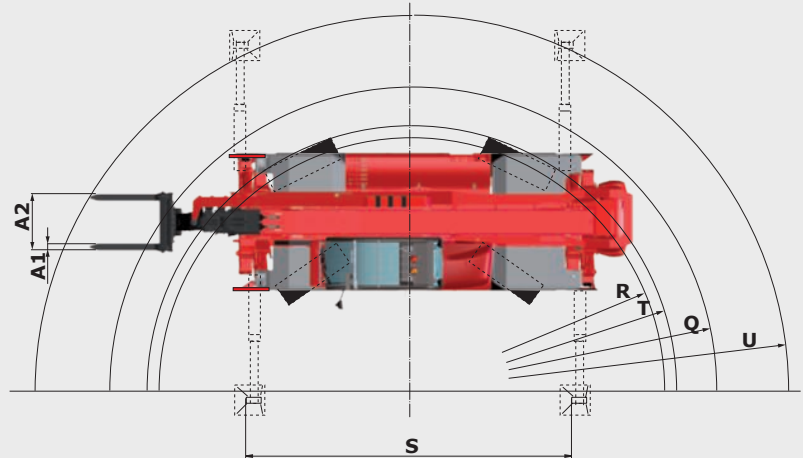
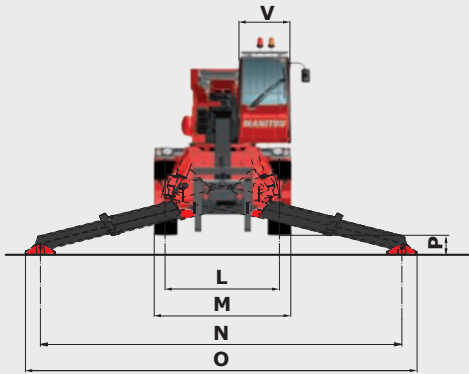

mm	MRT/MRT-X 3255
A	1200
A1	130
A2	1028
A3	60
B	383
C	8114
C1	8412
D	6568
E	1409
F	3750
G	1409
H1	431
H2	420
I	3002
J	3205
J1	3306
K	3803
K1	519

mm	MRT/MRT-X 3255
L	2064
M	2499
N	6490
O	7100
P	350
P2	14
P3	20
P4	20
Q	5560
R	4690
S1	5945
S2	6490
T	4910
U	7000
V	933
Y	12°
Z	105°

Rotation on extended stabilizers with forks

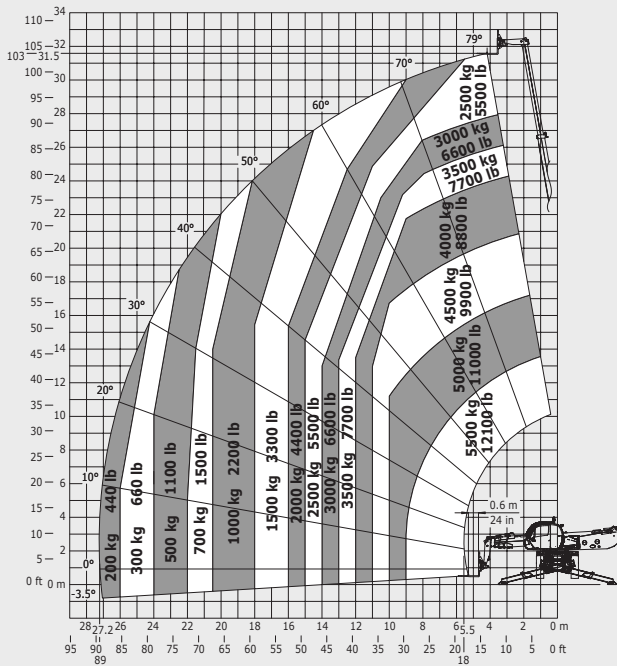

Rotation on extended stabilizers with 7200 kg winch

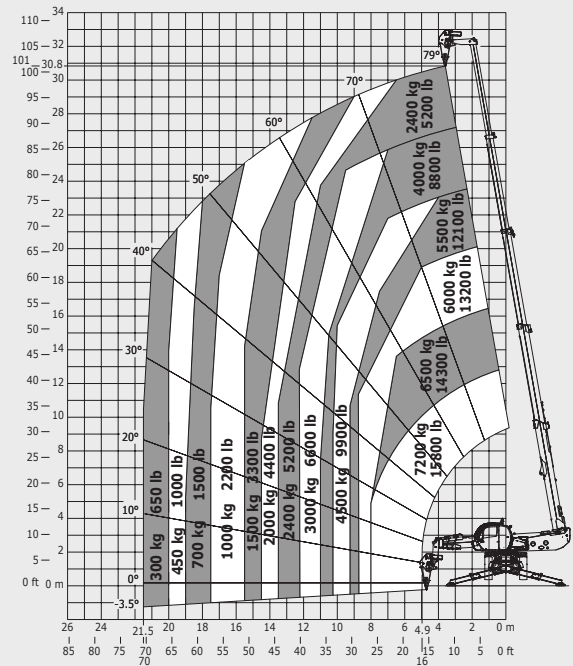

This brochure describes versions and configuration options for Manitou products which may be fitted with different equipment. The equipment described in this brochure may be standard, optional or not available depending on version. Manitou reserves the right to change the specifications shown and described at any time and without prior warning. The manufacturer is not liable for the specifications given. For more information, contact your Manitou dealer. Non-contractual document. Product descriptions may differ from actual products. List of specifications is not comprehensive. The logos and visual identity of the company are the property of Manitou and may not be used without authorisation. All rights reserved. The photos and diagrams contained in this brochure are provided for information only.



MRT & MRT-X 3255

PRIVILEGE +

Rotation on extended stabilizers
with **365/1000 kg platform**

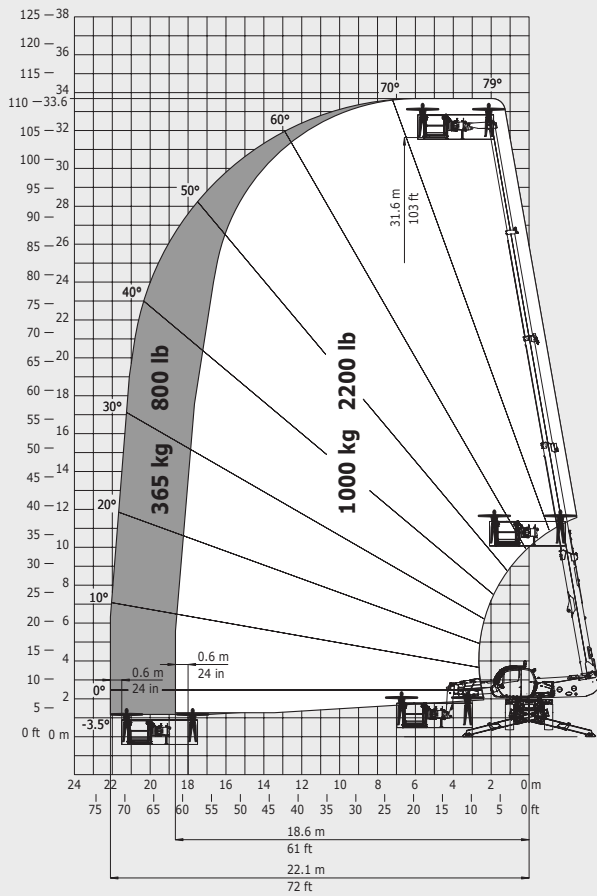

Rotation on extended stabilizers
3D positive / négative

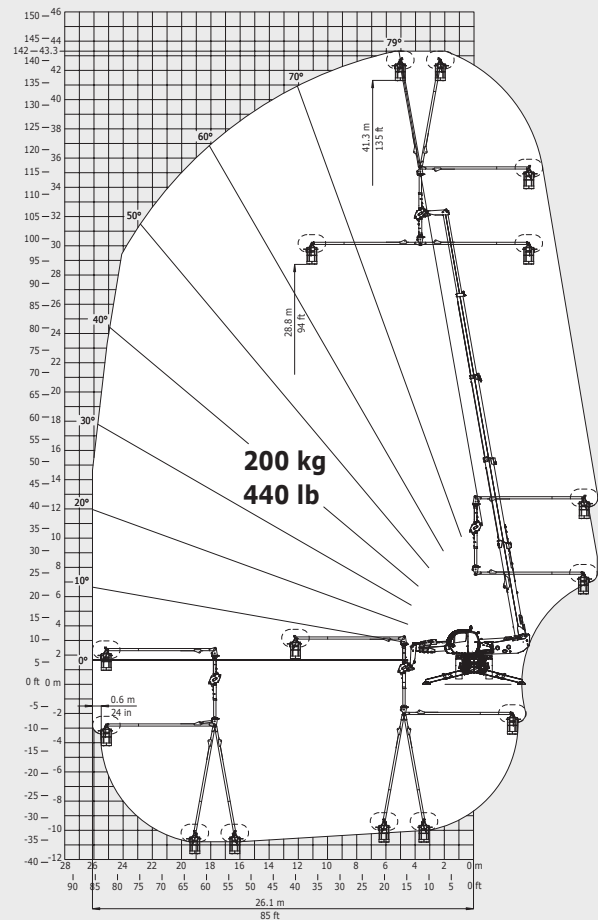

Rotation on extended stabilizers
with **5000 kg winch**

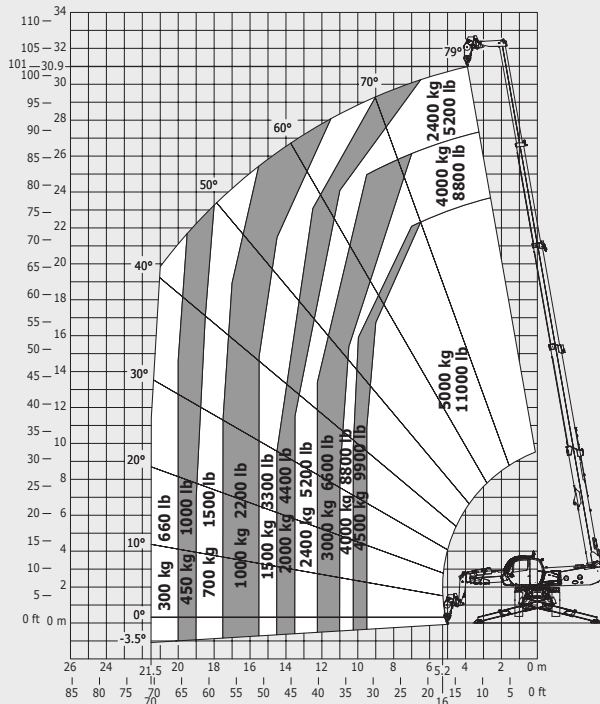

Rotation on extended stabilizers
with **1500 kg jib**

