

Technical sheet

MLT 733-115 LSU

Telehandlers



Capacities	Metric	Imperial
Max. capacity	3300 kg	7275 lbs
Max. lifting height	6.90 m	22 ft 7 in
Max. outreach	3.90 m	12 ft 9 in
Reach at max. height	0.90 m	2 ft 11 in
Weight and dimensions		
Unladen weight (with forks)	7015 kg	15465 lbs
m4 - Ground clearance	0.44 m	17 in
l2 - Overall length to carriage	4.85 m	15 ft 1 in
y - Wheelbase	2.81 m	9 ft 2 in
b4 - Overall width of cab	0.95 m	3 ft 1 in
b1 - Overall width	2.39 m	7 ft 10 in
h17 - Overall height	2.38 m	7 ft 9 in
a4 - Crowd angle	13 °	13 °
a5 - Dump angle	134 °	134 °
Wa1 - External turning radius (over tyres)	3.92 m	12 ft 1 in
Standard tyres	460/70 R24 159A8 A580 - Alliance	460/70 R24 159A8 A580 - Alliance
Performances		
Lifting	6.75 s	6.75 s
Lowering	5.65 s	5.65 s
Extension	6.50 s	6.50 s
Retraction	3.90 s	3.90 s
Crowd	3.15 s	3.15 s
Dump	2.55 s	2.55 s
Engine		
Brand	Deutz	Deutz
Environmental norm	Stage IV / Tier 4 Final	Stage IV / Tier 4 Final
Model	TCD 3.6 l	TCD 3.6 l
Number of cylinders - Cubic capacity	4 - 3621 cm ³	4 - 220 in ³
Power	116 hp / 85 kW	116 hp / 85 kW
Max. torque	410 Nm at 1600 rpm	302 ft.lbs at 1600 rpm
Laden drawbar pull	7380 daN	-
Reversible fan	Optional	Optional
Cooling system	4 radiators (water + intercooler + hydraulic oil + transmission oil)	4 radiators (water + intercooler + hydraulic oil + transmission oil)
Transmission		
Type	Torque Converter with box Powershuttle	Torque Converter with box Powershuttle
Number of gears (forward/reverse)	4/4	4/4
Max. travel speed (may vary according to applicable regulations)	32 km/h	20 mph
Differential lock	Limited slip differential on front axle	Limited slip differential on front axle
Parking brake	Manual parking brake	Manual parking brake
Service brake	Hydraulic oil immersed multi-disc braking on front & rear axles	Hydraulic oil immersed multi-disc braking on front & rear axles
Hydraulics		
Hydraulic pump type	Load sensing pump	Load sensing pump
Hydraulic flow - Pressure	150 l/min - 270 bar	40 gpm - 3916 psi
Tank capacities		
Hydraulic oil	135 l	36 US gal.
Fuel	120 l	32 US gal.
Diesel Exhaust Fluid (AdBlue® type)	10 l	3 US gal.

Noise & vibration		
Noise at driving position (LpA) tested following NF EN 12053 norm	76 dB(A)	76 dB(A)
Environmental noise LwA	105 dB(A)	105 dB(A)
Vibration to whole hand / arm	<2.5 m/s ²	<8.2 ft/s ²
Miscellaneous		
Safety	Tractor homologation EN 15000 Norm Cab ROPS - FOPS Level 2	Tractor homologation EN 15000 Norm Cab ROPS - FOPS Level 2

Tyre options

Optional tires	Overall machine height	Overall machine width
Trelleborg - 460/70 R24 159A8 TH400	2.37 m	2.40 m
Trelleborg - 500/70 R24 164A8 TH400	2.39 m	2.43 m
Michelin - 500/70 R24 164A8 XMCL	2.39 m	2.44 m
Michelin - 460/70 R24 159A8 Bibload	2.37 m	2.40 m
Michelin - 500/70 R24 164A8 Bibload	2.39 m	2.44 m
Nokian - 460/65 R24 159A8 Tri Steel	2.36 m	2.37 m
Michelin - 15.5 R25 XHA	2.37 m	2.33 m
Michelin - 460/70 R24 159A8 XMCL	2.37 m	2.40 m

Options / Finishing

S : Standard / O : Optional / - : Not available

	Classic	Premium	Elite
General			
Self cleaning air prefilter	S	S	-
Auto reversing fan	O	O	-
Boom suspension "Active CRC"	O	O	-
Additional fuel tank (25 l)	O	O	-
Manual towing hitch	S	S	-
Manual rotating towing hitch on counterweight	S/O**	S/O**	-
Automatic rotating towing hitch on counterweight	O	O	-
Ladder hitch with choice of hooks	O	O	-
Comfort			
Mechanical cloth seat (GRAMMER)	S	-	-
Air suspension cloth seat (GRAMMER)	O	S	-
Low frequency air suspension cloth seat (GRAMMER)	O	O	-
Low frequency air suspension cloth seat with heating	O	O	-
Tuner car radio (50 W)	S	-	-
Bluetooth car radio with integrated microphone (100 W)	O	S	-
Bluetooth car radio with extra microphone (100 W)	O	O	-
Manual air conditioning	O	S	-
Automatic air conditioning	O	O	-
"Harmony" display	S	S	-
Hydraulic			
Easy Connect System (ECS)	S	S	-
Continuous flow hydraulics	O	O	-
Attachment hydraulic locking	O	O	-
Return pipe to hydraulic oil tank	O	O	-
1 pair of pre-fitted Double Action rear hydraulic couplers	O	O	-
Electrovalve for 2 hydraulic functions (on boom head)	O	O	-
Hydraulic trailer brake	S/O**	S/O**	-
Electricity / Safety			
Audio warning on reverse movements	O	O	-
Front and rear work lights (x4: 2 front + 2 rear)	S	-	-
Front and rear LED work lights (x4 : 2 front + 2 rear)	O	S	-
Lateral wiper	O	O	-
Extra front wiper	O	S	-
LED work lights on boom head	O	O	-

Load chart

Created on October 6, 2017 8:27 AM

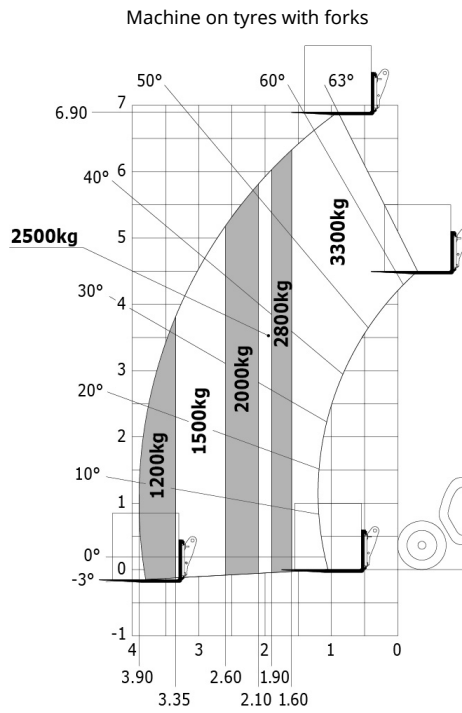

Rough terrain load chart (EN 1459 B)

Dimensional drawing

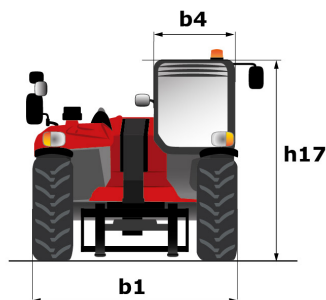
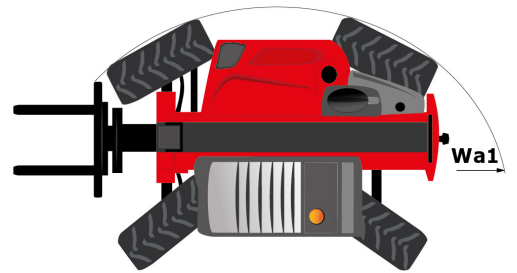
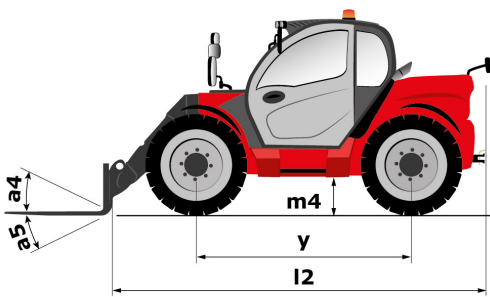

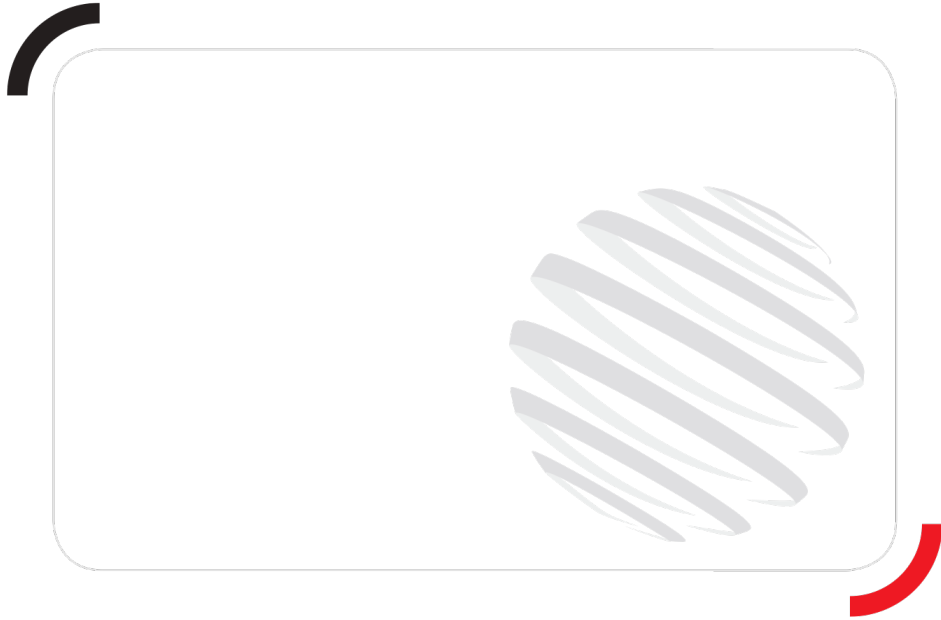

Siège Social
430 rue de l'Aubinière - 44150 Ancenis Cedex - France
Tel: +33(0)2 40 09 10 11 - Fax: +33 (0)2 40 09 10 97
www.manitou.com



This brochure describes versions and configuration options for Manitou products which may be fitted with different equipment. The equipment described in this brochure may be standard, optional or not available depending on version. Manitou reserves the right to change the specifications shown and described at any time and without prior warning. The manufacturer is not liable for the specifications given. For more information, contact your Manitou dealer. Non-contractual document. Product descriptions may differ from actual products. List of specifications is not comprehensive. The logos and visual identity of the company are the property of Manitou and may not be used without authorisation. All rights reserved. The photos and diagrams contained in this brochure are provided for information only.

MANITOU BF SA - Limited company with board of directors - Share capital: 39,547,824 euros - 857 802 508 RCS Nantes