

TECHNICAL DATA SHEET

MT 1335
Manitou Telescopic

easy



	MT 1335 easy	MT 1335 H easy	MT 1335 HA easy
Lifting			
Max. capacity		3500 kg	
Max. lifting height		12.55 m	
Max. outreach		8.75 m	
Break-out force with bucket (ISO 8313)		6400 daN	
Unladen time			
Lifting		10.0 s	
Lowering		8.0 s	
Extension		14.0 s	
Retraction		10.0 s	
Crowd		4.0 s	
Dump		4.0 s	
Tyres		400 / 80 -24	
Braking			
Service brake		oil immersed multi-disc braking	
Parking brake		automatic negative parking brake	
Engine			
		DEUTZ - STAGE 3B - FINAL TIER 4	
Type		TD 3.6 L	
Cubic capacity		3621 cm ³	
Power		75 HP/55.4 kW	
Max torque		330 Nm	
Injection		direct	
Cooling		water	
Laden drawbar pull		8000 daN	
Transmission			
	torque converter	hydrostatic	
Reversing shift		electrohydraulic control	
Number of gears (forward/reverse)	4/4	3/2	
Drive wheels		4 wheel drive	
Steering mode		4 wheel steer - 3 steering modes	
Max. travel speed (may vary according to applicable regulations)		25 kph	
Hydraulics			
Pump		gear type with priority valve 125 l/min – 270 bar	
Capacities			
Hydraulic oil		125 l	
Fuel		120 l	
Unladen weight (with forks)	9100 kg	9200 kg	
Dimensions			
1. Front wheel centre to carriage		1.80 m	
2. Wheelbase		2.88 m	
3. Rear wheel centre to rear face		1.18 m	
4. Overall length to carriage		5.86 m	
5. Ground clearance		0.42 m	
6. Overall width of cab		0.88 m	
7. Inside tyre width		1.87m	
8. Overall width		2.28 m	
9. Overall width (stabilizers lowered)		2.28 m	
10. Overall height		2.42 m	
Turning radius (over tyres)		3.65 m	
Carriage rotation (crowd / dump)		12° /114°	
Standard forks (length x width x thickness)		1200 x 125 x 45 mm	
Frame levelling		in option	
Controls			
		JSM [®] (Multi-function joystick)	
Safety			
		Load limiter cut off system - EN 15000 norm ROPS / FOPS level II standard cab	
Noise and vibration			
Noise at driving position (LpA)		78 dB	
Environmental noise (LwA)		103 dB	
Vibration to whole hand/arm		<2.50 m/s ²	

Rough terrain load chart
Standard EN 1459B

Machine with forks on tyres

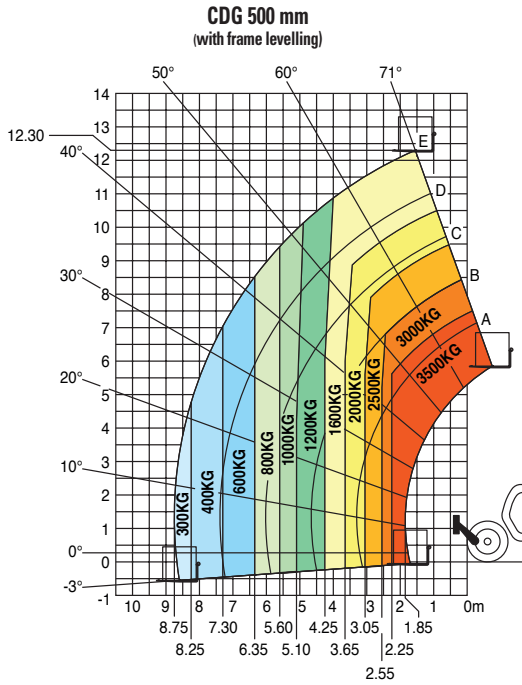

Machine with forks on stabilizers

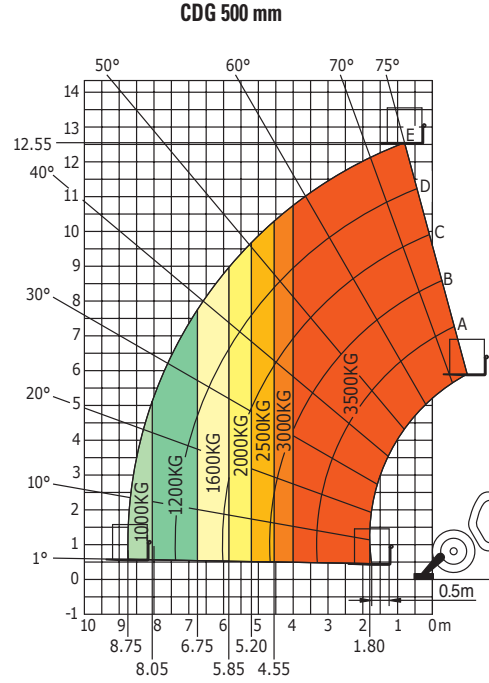

Machine with platform on stabilizers

(MT 1335 HA)

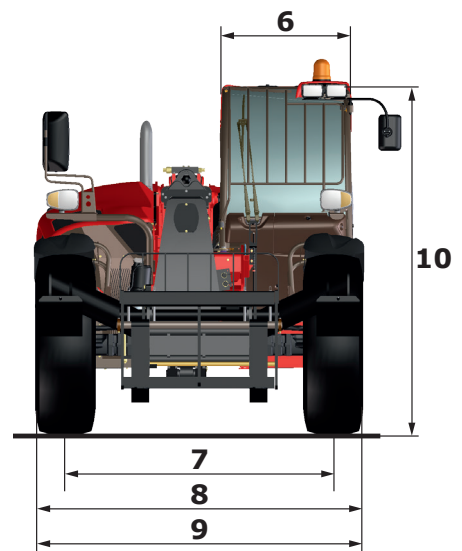
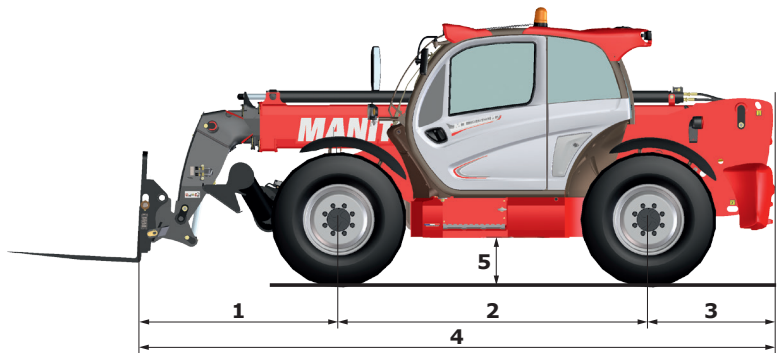
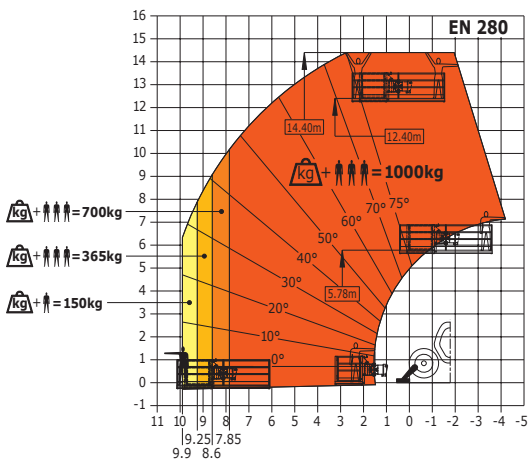

Your MANITOU dealer



Head office :
B.P. 249 - 430 rue de l'Aubinière - 44158 Ancenis Cedex - France
Phone.: +33 (0)2 40 09 10 11 - Fax: +33 (0)2 40 09 10 97
www.manitou.com

